

TREATMENT PLANT APPROVAL 18/2025
Plumbing and Drainage Regulation 2019, Part 4.

Approval

1. The AES-38 and AES-38-SPD variant of the **Advanced Enviro-Septic 38** (“the system”) described in the Specifications and Drawings in the attached Schedule, manufactured by **Presby Environmental Inc.** (“the manufacturer”) and supplied by **Chankar Environmental Pty Ltd** (ACN 148 175 455) (“the supplier”), have been assessed in accordance with:
 - (a) section 19 of the *Plumbing and Drainage Regulation 2019*
 - (b) the Queensland Plumbing and Wastewater Code, as published 26 June 2025.
2. A Treatment Plant Approval (TPA) is granted for a **Secondary quality** wastewater treatment system, subject to compliance by the manufacturer/supplier with the requirements of the *Plumbing and Drainage Act 2018* and the conditions of approval detailed below.
3. This approval, the conditions of approval, and the Schedule comprise the entire TPA document.
4. Subject to clause 8 below, any modification by the manufacturer/supplier to the design, drawings or specifications scheduled to this approval must be approved by the Chief Executive.

Conditions of approval

5. The manufacture, installation, operation, service, and maintenance of the system must conform with the conditions of this TPA.
6. This approval applies to the following variants of the Advanced Enviro-Septic 38 system:
 - AES-38
 - AES-38-SPD (with a liner and with or without disinfection)
7. The system, when tested in accordance with AS 1546.3:2017– On-site domestic wastewater treatment units, Part 3: Secondary treatment systems, and assessed by a certification accreditation body, was found to comply with the **Secondary quality** at 1,200 L per day level. The system must continue to meet the following requirements:

Table 2.1 (Abrev.) AS1546.3:2017 secondary effluent compliance criteria for an STS

Parameter	Secondary effluent	
	90% of Samples	Maximum
Five-day Biological Oxygen Demand (BOD ₅)	≤ 20 mg/L	30 mg/L
Total Suspended Solids (TSS)	≤ 30 mg/L	45 mg/L
<i>Escherichia coli</i> (<i>E. coli</i>)*	≤ 10 cfu/100 mL	30 cfu/100 mL
Free Available Chlorine (FAC) ^P	Minimum 0.5 mg/L [†]	N/A
Turbidity [§]	N/A	10 NTU

* where disinfection is required

^P where chlorine disinfection is required

[†] minimum level, not 90% of samples

[§] where UV light is used for disinfection

8. System design and installation must be consistent with the Specifications and Drawings contained in the Schedule and incorporate:
 - (a) a 3,100 L baffled septic tank
 - (b) a multi-outlet distribution box installed to proportionally distribute wastewater per AES pipe from the septic tank to the modules



TREATMENT PLANT APPROVAL 18/2025
Plumbing and Drainage Regulation 2019, Part 4.

- (c) a configuration of pipes consistent with the engineering diagrams as shown in the Schedule.
- (d) An inspection/sampling point must be permanently installed in the sand immediately below the half-way point of the AES treatment bed and between the pipe modules. Where a system is installed in a sloping basal area, an additional inspection/sampling point must be installed at the lowest point of the basal area.

Note: The AES system design must adhere to the manufacturer’s specifications as outlined in the AES Design Calculator[®] and the AES Design and Installation Manual.

- (e) Where gravity flows cannot sufficiently transfer wastewater from the septic tank to the AES treatment pipes, the system may include the following components:
 - i. a pump well, designed in accordance with AS/NZS 1547:2012– On-site domestic wastewater management, with a capacity to provide at least 24 hours of emergency storage above the high-water level alarm sensor.
 - ii. a submersible pump equipped with a high-level alarm, compliant with AS 1546.3:2017– On-site domestic wastewater treatment units, Part 3: Secondary treatment systems. The pump should be a Davey D25VA or similar, capable of delivering a flow rate between 40 litres per minute and 76 litres per minute at a minimum head of 6 metres. If site conditions require a higher head, an appropriately sized pump must be installed.

Note: *Any change to a system other than those listed in clause 8 will be considered a design change.*

9. Permitted use of the effluent under this TPA is as follows:

System design	Irrigation type
<ul style="list-style-type: none"> • AES-38 • AES-38-SPD with a liner and a secondary subsurface land application area 	sub-surface irrigation
<ul style="list-style-type: none"> • AES-38-SPD with a liner and disinfection 	surface irrigation

- 10. Each system must be serviced as specified by the designer and undertaken in accordance with the owner’s manual.
- 11. Routine maintenance of the system at set intervals, other than septic tank sludge levels, is not stipulated by the manufacturer/supplier. In the event of a failure of a system’s land application area, an authorised person may need to rejuvenate the land application area and follow the procedure as set out in the manufacturer/supplier’s design and installation manual.
- 12. Each system must be supplied with:
 - (a) a copy of this TPA document
 - (b) details of the system
 - (c) instructions for authorised persons for its installation
 - (d) a copy of the owner’s manual to be given to the owner at the time of installation
 - (e) detailed instructions for authorised service personnel for its operation and maintenance.

TREATMENT PLANT APPROVAL 18/2025
Plumbing and Drainage Regulation 2019, Part 4.

13. At each anniversary of the TPA issue date, the supplier must submit to the Chief Executive a list of all systems installed in Queensland during the previous 12 months. Where the Chief Executive is notified of any system failures, the Chief Executive may randomly select several installed systems for audit. The Chief Executive will notify the supplier's nominated NATA accredited laboratory which systems are to be audited for BOD₅ and TSS. The sampling and testing of the selected systems, if required, is to be done at the supplier's expense. The following results must be reported to the Chief Executive:
 - (a) address of premises
 - (b) date inspected and sampled
 - (c) sample identification number
 - (d) BOD₅ for influent and effluent
 - (e) TSS for influent and effluent.
14. The Chief Executive may, by written notice, cancel this approval if the manufacturer/supplier fails:
 - (a) to comply with one or more of the conditions of approval.
 - (b) within 30 days, to remedy a breach, for which a written notice been given by the Chief Executive.
15. This approval may only be assigned with the prior written consent of the Chief Executive.
16. Where there is any inconsistency between the content of this approval and the *Plumbing and Drainage Act 2018* (including any associated regulation and/or codes), the provisions of the *Plumbing and Drainage Act 2018* will apply and must be adhered to.
17. This approval expires on **4 February 2031**, unless cancelled earlier in accordance with clause 14 above.

Michael Essery



Director

Strategic Policy (Plumbing, Drainage and Special Projects)

Date approved: 5 February 2026



TREATMENT PLANT APPROVAL 18/2025
Plumbing and Drainage Regulation 2019, Part 4.

SCHEDULE

AES-38 and AES-38-SPD

Attachment 1: SAI GLOBAL Certificate SMK40355

Attachment 2: AES – Owner’s manual

Attachment 3: AES-38 and AES-38-SPD Product Specifications and Schematic diagrams

Attachment 1: SAI GLOBAL Certificate SMK40355

STANDARDSMARK
LICENCE



Intertek SAI Global hereby grants:
Chankar Environmental Pty Ltd

ABN 74 148 175 455

Unit 4, 100 Rene Street, Noosaville, QLD 4566, Australia

StandardsMark Licence

Manufactured to:

AS 1546.3:2017 - On-site domestic wastewater treatment units - Secondary treatment systems

"the StandardsMark Licensee "the right to use the STANDARDSMARK as shown below only in respect of the goods described and detailed in the Schedule which are produced by the Licensee or on behalf of the Licensee* and which comply with the appropriate Standard referred to above as from time to time amended. The Licence is granted subject to the rules governing the use of the STANDARDSMARK and the Terms and Conditions for certification and licence. The Licensee covenants to comply with all the Rules and Terms and Conditions.

Certificate No:
SMK40355

Originally Certified:
5 April 2024

Current Certification:
16 December 2024

Issued:
17 December 2024

Expires:
4 April 2029



Calin Moldovean
President, Business Assurance

SAI Global Certification Services Pty. Ltd.
Level 7 Suite 7.01 45 Clarence Street
Sydney NSW 2000 Australia



SCHEDULE TO STANDARDSMARK LICENCE



Intertek SAI Global hereby grants: **Chankar Environmental Pty Ltd**

Unit 4, 100 Rene Street, Noosaville, QLD 4566, Australia

Manufactured to:

AS 1546.3:2017 - On-site domestic wastewater treatment units - Secondary treatment systems

Model identification of the goods on which the STANDARDSMARK may be used:

Brand Name & Model ID	Treatment Capacity (Litre / Day)	Treatment Type	Compliance Type	Disinfection Method	Date Endorsed
AES-38	1200 L/day	Sand filter with geofabric wrapped pipe distribution system. (Ave Total Nitrogen 49 mg/L = 18.3% reduction, Ave Total Phosphorus 7.8 mg/L = 36% reduction)	Secondary	None	11 Dec 2024
AES-38-SPD	1200 L/day	Sand filter with geofabric wrapped pipe distribution system. (Ave Total Nitrogen 49 mg/L = 18.3% reduction, Ave Total Phosphorus 7.8 mg/L = 36% reduction)	Secondary	Chlorine Tablets	11 Dec 2024

End of Record

Certificate No: SMK40355

Issued Date: 17 December 2024

This schedule supersedes all previously issued schedules

* For details of manufacture, refer to the licensee

The STANDARDSMARK is a registered certification trademark of SAI Global Pty Limited (A.C.N. 050 644 642) and is issued under licence by SAI Global Certification Services Pty Limited (ACN 108 716 669) ("INTERTEK SAI Global") Level 7 Suite 7.01 45 Clarence Street Sydney NSW 2000 Australia and subject to the INTERTEK SAI Global Terms and Conditions for Certification. In the issuance of this certificate, INTERTEK SAI Global assumes no liability to any party other than to the Client, and then only in accordance with the agreed upon Certification Agreement. This certificate's validity is subject to the organization maintaining their system in accordance with INTERTEK SAI Global requirements for systems certification. This certificate may only be reproduced in its entirety and remains the property of INTERTEK SAI Global, to whom it must be returned upon request. Refer to <https://register.saiglobal.com/> for the list of product models.



Page: 2 of 2

ADVANCED ENVIRO-SEPTIC OWNER’S MANUAL AES-38 & AES-38-SPD



Distributor

Chankar Environmental Pty Ltd

4/100 Rene Street
Noosaville QLD 4566
(07) 5474 4055
www.enviro-septic.com.au
info@enviro-septic.com.au

Manufactured by Presby Environmental Inc.
143 Airport Rd, Whitefield, NH 03598
United States

Advanced Enviro-Septic™ U.S. Brevet nos. 6,461,078; 5,954,451;
6,290,429;
6,899,359; 6,792,977; 7,270,532 and 5,606,786. Other patents pending.

Enviro-Septic® is a trademark of Presby Environmental, Inc.
Advanced Enviro-Septic™ is a trademark of Presby Environmental, Inc.
Bio-Accelerator™ is a trademark of Presby Environmental, Inc.

Ver: FV4

10/2024

IMPORTANT SAFETY INSTRUCTIONS



It is extremely dangerous even potentially deadly to open a septic tank, pumping station or any enclosed space that is part of a wastewater treatment system. This work must be done by a person trained in enclosed space working and rescue procedures who has the necessary equipment.

The action of the bacteria on the organic matter present in the wastewater produces gases such as carbon gas (CO₂), methane gas (CH₄) and Hydrogen Disulphide (Rotten Egg Gas H₂S). The H₂S present in the septic tank or a pumping station can cause the death of an individual in a matter of minutes.

This is why this work must be left to competent personnel.



Pipes are buried near your septic installation. Please speak to your contractor or the technical service of Advanced Enviro-Septic™ in order to take all the necessary precautions prior to digging or undertaking excavation jobs near your septic system.



Please be sure that the covers of the septic tank, the pumping station, and the sampling device are always in place and that they remain accessible at all times for periodic inspections and interventions when necessary.

Please be sure that the covers of the septic tank, the pumping station, and the sampling device are always in place and that they remain accessible at all times for periodic inspections and interventions when necessary.

Table of Contents

INTRODUCTION	4
THE PURPOSE OF THIS DOCUMENT	4
DESIGNATION OF ADVANCED ENVIRO-SEPTIC	4
DEFINITION OF THE ADVANCED ENVIRO-SEPTIC SYSTEM	4
WHAT TO DO IF A PROBLEM OCCURS?	4
CUSTOMER SERVICE AND TECHNICAL SUPPORT INFORMATION	4
CERTIFIED CONTRACTOR	5
ADVANCED ENVIRO-SEPTIC SYSTEM (AES)	6
AES CAPACITY	6
HOW DOES THE AES GRAVITY SYSTEM WORK?	6
OVERVIEW OF THE ADVANCED ENVIRO-SEPTIC SYSTEM	6
TREATMENT PROCESS OF THE ADVANCED ENVIRO-SEPTIC SYSTEM	6
ADVANCED ENVIRO-SEPTIC SYSTEM COMPONENTS	7
OPERATING THE ADVANCED ENVIRO-SEPTIC SYSTEM	7
INITIAL USE	7
INTERMITTENT USE OR PROLONGED ABSENCES	7
WASTEWATER VOLUME	7
IN THE BATHROOM	8
IN THE KITCHEN	8
FOR THE LAUNDRY	8
ELSEWHERE IN AND AROUND THE HOUSE	8
CHEMICALS FOR SEPTIC INSTALLATION	9
HEAVY MACHINERY AND MOTORISED VEHICLE TRAFFIC	9
VEGETATION	9
PRE-FILTER (SEPTIC TANK EFFLUENT FILTER)	9
ADVANCED ENVIRO-SEPTIC PIPE ROWS	9
VENT	9
SYSTEM SAND	9
PUMPING STATION	9
EMBANKMENT SURFACE ABOVE THE ENVIRO-SEPTIC SYSTEM	9
MAINTENANCE	10
AES MAINTENANCE CHART	10
SEPTIC TANK	10
PUMPS	11
SINGLE POINT DISCHARGE (SPD)	12
RESPONSIBILITIES	14
OWNER'S RESPONSIBILITIES	14
QUALIFIED PERSON	14
WARRANTY	15
AES PIPES	15
WARRANTY OTHER COMPONENTS	16
INFORMATION ON YOUR SYSTEM	17
INSTALL DETAILS	17
REGISTER OF MAINTENANCE	17

Introduction

Thank you for choosing the Advanced Enviro-Septic System for your wastewater treatment solution. This system was developed to treat domestic wastewater to Secondary standard. These instructions must be followed to ensure it maintains its treatment performance over many years.

Please read through this entire document and retain it in your files for future reference.

The purpose of this document

This user guide explains the proper use, procedures and inspections required in order to ensure the safe and efficient operation of your Advanced Enviro-Septic System for residential wastewater treatment.

It is the owner's responsibility to ensure that the system is used correctly and according to its treatment capacity. The owner must also ensure rules and regulations regarding council and government regulations are complied with.

Designation of Advanced Enviro-Septic

Name:	Advanced Enviro-Septic™ Wastewater System
Application:	Wastewater (sewage)
Class & Treatment Type:	The Advanced Enviro-Septic system meets the water quality performance criteria requirements of AS1546.3:2017 for models AES-38 and AES-38 SPD.

IMPORTANT: The system cannot be used to treat wastewater to make it potable. It treats residential wastewater to an acceptable level for it to be reintroduced back into the environment.

Definition of the Advanced Enviro-Septic System

The Enviro-Septic system is composed primarily of two main components: rows of Advanced Enviro-Septic™ pipe and layers of system sand. The Enviro-Septic system must have the wastewater primary treated via a septic tank with this transferred to the AES treatment pipes.

Model AES-38 has the treated water discharge directly into the soil beneath the treatment system through soil absorption.

Model AES-38 SPD has the treated wastewater collected by a liner and distributed to the Land Application Area via pumpwell. This treated effluent may or may not be the disinfected subject to the LAA method and regulatory requirements.

What to do if a problem occurs?

If during normal use of your septic system you notice any of the following problems:

- *Presence of abnormal odours in the house, around the septic system or emanating from sources of drinking water,*
- *Abnormally wet soil, presence of persistent puddles or odours in the area of the septic tank or the Enviro-Septic system,*
- *Slow flushing toilets or other plumbing in the home,*
- *Presence of abnormally abundant vegetation on the surface or around the septic tank or the Enviro-Septic system installation,*
- *Flooding in the area where the Enviro-Septic system is installed,*
- *Erosion of the land fill on or around the Enviro-Septic system,*
- *Alarm from the pumping station if such a device is part of your installation ... immediately contact your installer/plumber*

Customer service and technical support information

Please contact us if you need further information via the following:

Telephone: (07) 5474 4055

Email: info@enviro-septic.com.au

Web: www.enviro-septic.com.au

Certified contractor

The Advanced Enviro-Septic system must be installed by a licensed contractor, certified by Chankar Environmental. Certification is obtained by attending the online "Enviro-Septic Contractor Certification Course" which can be found on our web page www.enviro-septic.com.au.

The Advanced Enviro-Septic™ customer service team can also provide the names of contractors who have certification to install the Enviro-Septic system in your area.

Advanced Enviro-Septic System (AES)

Advanced Enviro-Septic System (AES)

AES capacity

The capacity of the system in Litres/Day can be obtained from the manufacturer plate located at the low vent.

Depending on the AES model being used, the treatment system may be limited by the capacity of the underlying soil to permit the infiltration and evacuation of wastewater. This should be evaluated by the designer authorised to create the design plans for your installation.

It is important to verify with the designer if the capacity of the soil permits complete infiltration and dispersion of the design wastewater load treated by the AES pipes installed.

How does the AES-38 gravity system work?

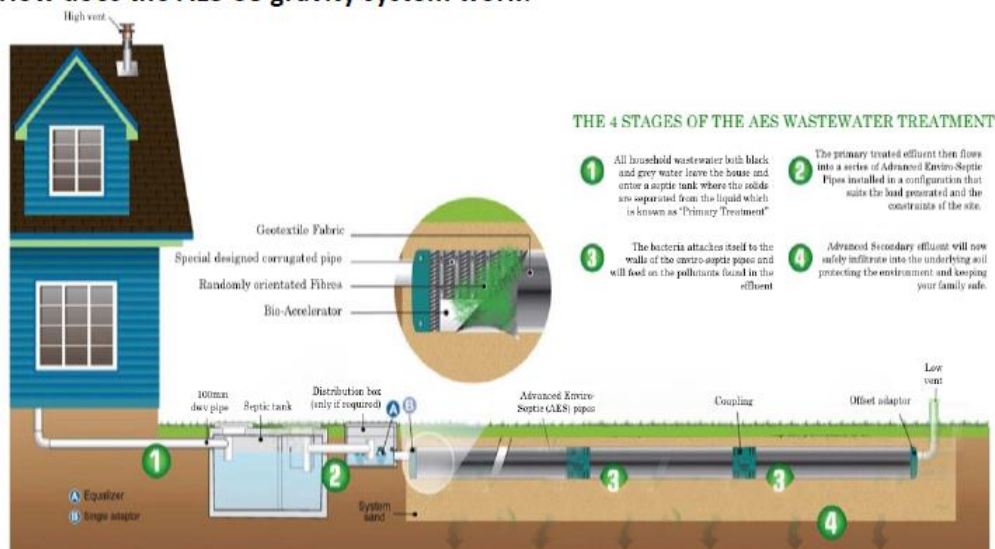

Overview of the Advanced Enviro-Septic System

The Advanced Enviro-Septic system is a passive technology which assists the increase in bacteria responsible for the treatment of domestic wastewater. It is comprised mainly of two main components which are:

- Rows of Advanced Enviro-Septic pipes.
- System sand.

The Advanced Enviro-Septic system must have the wastewater primary treated via a septic tank and then discharge to the LAA after treatment in the pipes depending on the AES Model used.

Treatment process of the Advanced Enviro-Septic System

Wastewater, including kitchen, bathroom, shower and toilet, are all discharged from the household into a standard septic tank with the minimum size, in Australia, of 3,000L.

The septic tank acts as a primary treatment reducing the concentration of food sources and suspended solids by approximately 50%. There is no available oxygen in this pre-treatment making the process anaerobic or no oxygen.

This process solubilises the BOD (fermentation and pre-acidification), converts nitrogenous compounds to ammonia, removes inorganic contaminants, homogenises the wastewater and provides a buffer against any toxic or disinfecting compounds before the AES treatment system.

This pre-treated waste then discharges into the AES treatment pipes. Here, the waste is passively aerobically treated using air drawn passively through the pipes. The organic solids are retained in the pipes and undergo continuous aerobic oxidation and the ammonia is oxidised to nitrate.

Operating the Advanced Enviro-Septic System

The AES pipe is placed, during installation, over a 300mm bed of specifically graded clean coarse sand. This acts as a polishing layer that uses both aerobic and anoxic treatment as the effluent passes through it. As the effluent drains through this layer, denitrification, BOD removal and final polishing occurs.

After treatment in the AES pipes, the treated effluent is discharged into the system sand where it percolates into the surrounding soil at secondary standard.

Advanced Enviro-Septic System Components

Your AES system installation includes several components. All these components are part of the treatment chain for your installation. Table 1 below presents the list of these elements and presents a summary of inspections required for each component. It should be noted, however, that some of these are only used when site conditions require them.

Table 1 AES System Components

Component	Function	Follow-up needed	Frequency	Responsible for follow-up
Septic Tank	Primary wastewater treatment	Periodic emptying/pumping out	According to standards and regulations in effect. Usually every 3-5 years.	Owner is responsible to have work done by a qualified contractor.
Vent Low & High	To allow circulation of air in the enviro-septic system	Ensure there is access to this device with the opening clear & clean	Regularly	Homeowner
Enviro-Septic pipes	Treat and distribute wastewater	Ensure AES pipes are not affected by tree roots or stormwater	No	No
System sand	To complete the treatment process and to improve the drainage	No	No	No
Pumping Station (when installed)	Pump septic tank effluent to the Enviro-Septic system	According to manufacturer's specifications	According to manufacturer's specifications	According to manufacturer's specifications

Operating the Advanced Enviro-Septic System

Initial Use

The use and maintenance of an Advanced Enviro-Septic System is relatively simple. In general, following the rules below will assist trouble free operation of your system for years to come.

At the time of installation, the septic tank must be filled with clear water. If a pumping station is used, the contractor will verify that it is functioning correctly at the time of installation. The homeowner must make sure that there is adequate electricity to safely operate the equipment including the high-level alarm.

Intermittent Use or Prolonged Absences

The Enviro-Septic system is a passive wastewater treatment system. When properly installed, it requires no special requirements when used intermittently or after a prolonged absence.

Wastewater Volume

Large quantities of wastewater that leave the house and enter the Enviro-Septic System in a short period of time could have a negative impact on the effectiveness of the treatment. High levels of infiltration can cause excessive agitation in the septic tank and sludge and/or scum can be pushed through into the AES treatment system and infiltration bed.

You must ensure that the volume of wastewater entering the Enviro-Septic System is within the design daily load as specified by your designer and stamped on the AES Plate located on your low vent.

Operating the Advanced Enviro-Septic System

The AES pipe is placed, during installation, over a 300mm bed of specifically graded clean coarse sand. This acts as a polishing layer that uses both aerobic and anoxic treatment as the effluent passes through it. As the effluent drains through this layer, denitrification, BOD removal and final polishing occurs.

After treatment in the AES pipes, the treated effluent is discharged into the system sand where it percolates into the surrounding soil at secondary standard.

Advanced Enviro-Septic System Components

Your AES system installation includes several components. All these components are part of the treatment chain for your installation. Table 1 below presents the list of these elements and presents a summary of inspections required for each component. It should be noted, however, that some of these are only used when site conditions require them.

Table 1 AES System Components

Component	Function	Follow-up needed	Frequency	Responsible for follow-up
Septic Tank	Primary wastewater treatment	Periodic emptying/pumping out	According to standards and regulations in effect. Usually every 3-5 years.	Owner is responsible to have work done by a qualified contractor.
Vent Low & High	To allow circulation of air in the enviro-septic system	Ensure there is access to this device with the opening clear & clean	Regularly	Homeowner
Enviro-Septic pipes	Treat and distribute wastewater	Ensure AES pipes are not affected by tree roots or stormwater	No	No
System sand	To complete the treatment process and to improve the drainage	No	No	No
Pumping Station (when installed)	Pump septic tank effluent to the Enviro-Septic system	According to manufacturer's specifications	According to manufacturer's specifications	According to manufacturer's specifications

Operating the Advanced Enviro-Septic System

Initial Use

The use and maintenance of an Advanced Enviro-Septic System is relatively simple. In general, following the rules below will assist trouble free operation of your system for years to come.

At the time of installation, the septic tank must be filled with clear water. If a pumping station is used, the contractor will verify that it is functioning correctly at the time of installation. The homeowner must make sure that there is adequate electricity to safely operate the equipment including the high-level alarm.

Intermittent Use or Prolonged Absences

The Enviro-Septic system is a passive wastewater treatment system. When properly installed, it requires no special requirements when used intermittently or after a prolonged absence.

Wastewater Volume

Large quantities of wastewater that leave the house and enter the Enviro-Septic System in a short period of time could have a negative impact on the effectiveness of the treatment. High levels of infiltration can cause excessive agitation in the septic tank and sludge and/or scum can be pushed through into the AES treatment system and infiltration bed.

You must ensure that the volume of wastewater entering the Enviro-Septic System is within the design daily load as specified by your designer and stamped on the AES Plate located on your low vent.

Operating the Advanced Enviro-Septic System

You must ensure that the volume of wastewater entering the Enviro-Septic System is within the design daily load as specified by your designer and stamped on the AES Plate located on your low vent.

After installation, if changes are made to the residence, (e.g. addition of a bedroom), please contact the designer of the Enviro-Septic System. A redesign may be required, depending on changes made to the dwelling.

In the Bathroom

Do:	Don't
<ul style="list-style-type: none"> • Immediately repair any leaking faucet or toilet. • Use a reasonable quantity of toilet paper. • Minimise or avoid bleach, antiseptic disinfectants, and ammonia acids in the system. 	<ul style="list-style-type: none"> • Use disinfectant in tablet (puck) form, whether it is placed in the basin or the tank. • Put cigarettes, cigarette butts or medication in the toilet. • Put paper towels, paper napkins or other personal hygiene products in the toilet.

In the Kitchen

Do:	Don't
<ul style="list-style-type: none"> • Repair any leaking taps. • Use dish soap or dishwasher soap that is low in phosphate. (0 to 5%) • Use the necessary quantity of soap to do the work. <i>Take note that the necessary quantity is often less than suggested by the manufacturer.</i> • Use biodegradable soap, low-phosphorus or phosphorus free detergents. 	<ul style="list-style-type: none"> • Use a food waste disposal unit in your sink that is connected to your septic installation. If you do have a waste disposal unit, your septic tank may require more frequent pump out to remove sludge build up. • Dispose of vegetables, meats, fat, oil, coffee beans, citrus products or other items into the septic system.

For the Laundry

Do:	Don't
<ul style="list-style-type: none"> • Use phosphate free detergent, preferably in liquid form. If it is not possible, use biodegradable powder detergent. • Use the minimum quantity of soap to do the work. Take note that the minimum quantity is often less than that suggested by the manufacturer. • Minimize the volume of water used for the laundry according to the quantity of clothing to wash. • Try to spread your loads of laundry throughout the week. 	<ul style="list-style-type: none"> • Put harsh chemicals or products into the system (e.g. paint, nappies)

Elsewhere in and around the House

Do:	Don't
<ul style="list-style-type: none"> • Divert drainage and rainwater away from the surface of the Advanced Enviro-Septic System. • All vents should be mosquito-proofed to prevent mosquitoes from breeding in the tank. • Roof and surface water should be redirected away from absorption trenches. 	<ul style="list-style-type: none"> • Discharge water softener backwash into your septic system. (If applicable) • Discharge any water from swimming pool filters, spas or other appliances that discharge chlorinated water into your septic system. • Let water from sump pumps, roof drains (gutters) and drainage pipes discharge into the septic system. • Dispose of solvents, paints, antifreeze, engine oil or other chemicals in the septic system. This includes water used to wash brushes or rollers that were used with latex paint. (latex paint contains elements that are harmful to septic systems) • dispose animal litter in the septic installation.

Operating the Advanced Enviro-Septic System

Chemicals for septic Installation

Your Enviro-Septic System does not require any starting enzymes, cleaning or other additives. The bacteria that carry out the treatment are naturally present in raw domestic sewage. Any chemicals or additives added to the Enviro-Septic System may kill these good bacteria.

Heavy machinery and motorised vehicle traffic

No vehicle or heavy machinery must be driven on the treatment system, whether it is before, during or after its construction. Heavy machinery or motorised vehicle traffic on the soil closes the natural pores of the soil which reduces its permeability and allows for pounding and the accumulation of water.

Heavy vehicles may also damage the AES Treatment Pipes.

Vegetation

The surface of the Advanced Enviro-septic system must be planted with grass. The grass must be cut regularly in order to encourage growth without the use of fertilisers. Vegetation cover contributes to the removal of nitrogen and phosphorus.

It is important **not** to plant trees or other plants with invasive roots within 3 meters of the Advanced Enviro-Septic system installation footprint.

Pre-filter (Septic tank effluent filter)

Effluent filter equipment is not necessary at the exit of the septic tank.

If the effluent filter is installed it must be cleaned regularly according to the maintenance and inspection procedures provided by the manufacturer.

Advanced Enviro-Septic Pipe Rows

Under normal use, the rows of Advanced Enviro-Septic pipe do not require maintenance. It is normal to find fluctuation of the water level in the pipes. If the water level reaches 260mm, a rejuvenation of the Enviro-Septic System must be considered. A qualified person must carry out this procedure.

Vent

It is very important to ensure that good ventilation occurs so that the treatment system functions correctly. The vent(s) installed at the ends of the treatment system allow for passive air circulation. It is important to make sure that these vents are not blocked and that air can circulate freely at all times.

Air enters through the low vent, circulates through the rows of pipes and the septic tank and travels through the plumbing of the house to exit through the roof vent. There must be a difference of at least 3 meters, at all times, between the entry vent situated at the extremity of the Enviro-Septic system and the exit vent usually located on the roof or a high vent.

When a pumping station is used, a bypass pipe or an extra high vent must be used to ensure proper ventilation of the system.

System Sand

There is no maintenance to be done on the system sand during normal use of the Enviro-Septic System.

Pumping Station

In some cases, site constraints require the use of a pumping station to transfer primary wastewater after the septic tank to the inlet of the AES pipes. The owner is responsible to comply with the manufacturer's scheduled maintenance requirements of this equipment. (Including pump and alarm)

Embankment surface above the Enviro-Septic System

The surface located above the Enviro-Septic system must be covered with herbaceous vegetation. A slight slope must be given to the surface to assist with the drainage of rainwater towards the outside of the system. The grass must also be cut regularly. Any depression that could be result over time must be filled in order to avoid accumulation of water above the system and to prevent erosion.

Maintenance

Maintenance

AES Maintenance Chart

AES Model	Septic Tank	Septic Effluent Filter	Pumpwell Alarm	AES	Chlorine	Irrigation Area
AES-38	Desludge every 3-5 Years	If fitted, monthly by homeowner ¹	Replace pump or alarm if required	No maintenance required	Not applicable	Not applicable
AES-38-SPD	Desludge every 3-5 Years	If fitted, monthly by homeowner ²	Replace pump or alarm if required	No maintenance required	Service 12 months or as required	Service as required

Septic Tank

Septic Tank Introduction

The septic tank, preceding the Advanced Enviro-Septic System, must be pumped out every 3-5 years for normal residential use and/or combined sludge and scum level is 2/3 of the septic tank capacity. Please check current regulations or get in touch with relevant council or government authorities for further information.

If the septic tank is not emptied regularly, a large quantity of solids and grease in suspension will leave the septic tank and end up in the treatment system. This will, over time, affect the performance of the Enviro-Septic System.

At all times, a professional using the proper equipment, must carry out the pumping out of a septic tank. The owner is responsible to ensure his septic tank is pumped out according to council regulations. This work should always be done by a qualified person since it can be very dangerous to open a septic system without first taking the necessary precautions.

Note: It is the homeowner's responsibility to make sure that the septic tank lids are in their proper position and securely fastened. A lid that is not installed correctly can be harmful to the operation of the Enviro-Septic System.

Testing for Sludge Scum

The sludge/scum levels in a septic tank can be measure by:

- Engaging a registered plumber to test and advise.
- Using an approved measuring device such as a "Sludge Judge" to determine the sludge and scum depth.

A typical septic tank is shown below in **Figure 1**.

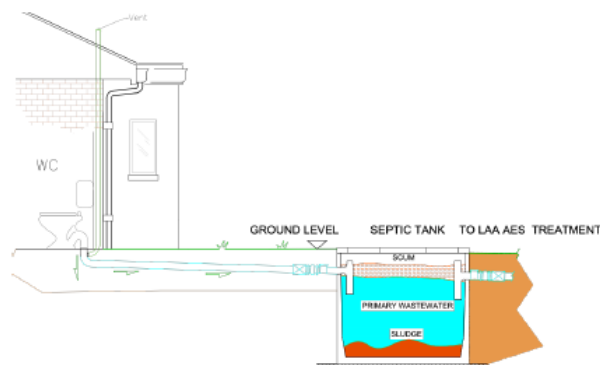

Figure 1 Typical Septic Tank showing Scum & Sludge Layers

1 AES-38 gravity systems do NOT require a Septic Tank outlet filter

2 AES-38 SPD gravity systems do NOT require a Septic Tank outlet filter

Maintenance

Once sampled with the approved device, determine the length of sludge plus the length of scum and divide this by the overall working depth of the septic tank.

For example:

- Working depth of septic tank 1,265mm
- Depth of scum 150mm
- Depth of sludge 300mm

Septic build-up = $(300+150)/1,265 = 36\%$. This is less than the maximum 60% therefore the septic tank does not need pumping out.

Another example:

- Working depth of septic tank 1,265mm
- Depth of scum 200mm
- Depth of sludge 600mm

Septic build-up = $(600+200)/1,265 = 63\%$. This is greater than the maximum 60% therefore the septic does need pumping out.

Pumps

Should a pump be installed as part of the AES system, then the following maintenance is recommended to be carried out by the homeowner every month:

- Inspect pumpwell for any build-up of scum and solids. Clean with a hose if required.
- Check pump operates without abnormal noises.

The following trouble shooting guide, Table 2 below, can be used should the system be operating incorrectly:

Table 2 Pump trouble shooting guide

Symptom	Possible Cause
Pump won't start	<ul style="list-style-type: none"> • Electrical connection or main switch problem. • Failed level switch. • Blockage in pump impellor.
Pump won't stop	<ul style="list-style-type: none"> • Failed level switch.
Pump keeps switching on and off	<ul style="list-style-type: none"> • Power supply fault to motor. • Faulty level switch. • Pump overload due to system blockage.
High motor current	<ul style="list-style-type: none"> • Motor power supply fault. • Blockage in system.
Low flow	<ul style="list-style-type: none"> • Discharge line blockage. • Pump failure.
High level alarm	<ul style="list-style-type: none"> • Level switch faulty. • High flow of sewage from household above design. • Pump failure.

Maintenance

Single Point Discharge (AES-38 SPD)

SPD Introduction

The Advanced Enviro Septic (AES) single point discharge is a standard AES with the treated effluent recaptured for disposal to the Land Application Area (LAA).

The AES SPD can be treated and dispersed via sub-surface trenches/beds, sub surface irrigation or above ground irrigation.

A flowsheet of a typical domestic AES SPD system is shown below in **Figure 2**:

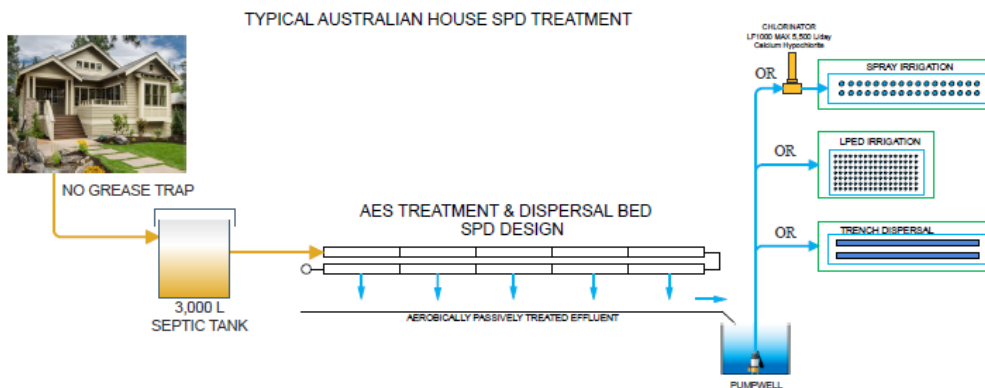

Figure 2 Typical domestic house AES SPD Process Flow

The method of disposal as specified by the qualified designer will determine the maintenance requirements of the system. These requirements must be detailed in the design report.

Your wastewater system must be maintained as per the recommendation set out in the designers' report, this document.

SPD Pump

The make and model of the pump installed shall be recorded with the as constructed plans. This will include contact details for the installation plumber should there be a pump failure. High level alarm instructions shall also be included.

Refer to Pumps on Page 11 for pump maintenance and troubleshooting.

Sub Surface Trenches/Beds

The AES SPD treated effluent is disposed of into the soil using a trench or bed without disinfection.

The LAA should be visually inspected at the same interval as the septic tank.

Sub Surface Irrigation

The AES SPD treated effluent is disposed into the soil via a sub-surface LAA dispersal system.

This method of treated effluent dispersal will require an inspection, based on the designers' recommendations, to ensure no blockages of the sub surface drippers and the back flushing system is working correctly as per the manufacturers maintenance requirements.

Disinfection

Disinfection may be required depending on the LAA disposal method adopted. If the designer adopts disinfection and specifies Chlorine tablets (Calcium Hypochlorite), a disinfection applicator suitable for this purpose, such as the Norweco LF1000, shall be used.

Chlorine tablet replenishment will be done at the frequency stated in the designers' report.

Maintenance

If a filter has been specified and installed into the treatment system, this is to be checked and cleaned as per the designers' recommendations.

Above Ground Irrigation

Disposal of AES SPD treated effluent to above ground irrigation must have an approved disinfection method as specified by the qualified system designer.

This method of treated effluent dispersal will require a service as specified by the system designer. Items checked include septic tank sludge level, sprinkler operation, clean filter if installed and restock chlorine tablets.

Chlorine to be Used for Sterilisation

The correct chlorine to be used to ensure correct disinfection of wastewater is Calcium Hypochlorite. Pool chlorine tablets containing TriChloroisocyanuric Acid or TriChlor are not effective in wastewater sterilisation and are detrimental to the surrounding environment.

You must NEVER mix Calcium Hypochlorite tablets with pool chlorine tablets as an explosive liquid reaction will take place.

It is recommended that the chlorinator be inspected every 12 months and topped up with the appropriate chlorine tablet.

Sampling Procedure

To test the effluent quality from an AES SPD the following procedure must be followed.

1. A live sample must be collected from the inlet to the pump well (do not take sample from effluent sitting in the pump well)
2. If the system has no flow, Pump the contents of the pump well back into the septic tank using a sump pump or extractor pump.
3. It will take a little time for the liquid to pass back through the septic tank and AES pipes before it can be collected from the inlet to the pump well.
4. BOD and TSS should be tested however systems with a disinfection apparatus should include E. coli and Free residual chlorine.
5. Samples to be placed in NATA or Equivalent Certified Laboratory supplied sample jars and correct date, sample location and Chain of Custody (COC) details filled in. To be transported to the lab in a cooled "Esky".
6. Only suitably qualified AES certified plumbers/drainers should undertake service and maintenance on an AES SPD.

Failure to follow these correct procedures may result in elevated test results that are not representative of the actual treatment values.

Responsibilities

Responsibilities

Owner's Responsibilities

The owner is responsible for:

- Using the Advanced Enviro-Septic system according to the instructions presented in the user guide.
- Pumping out the septic tank according to the regulations in effect.
- Maintaining the effluent filter (if required), the pumping station, the pressure distribution system or the automatic wastewater distributing valve according to manufacturer's specifications and recording the information if this equipment is part of the system.
- Ensuring that the vent openings are clear of any obstacle.
- Providing access at all times to the Enviro-Septic system.
- Adhering to the requirements of the applicable rules and regulations, with regards to the discharge standards of the system to the environment.

Qualified Person

The qualified person who carries out the design, installation, maintenance or inspections on any Advanced Enviro-Septic onsite sewage facility must hold the relevant state required qualification and have completed the free online Advanced Enviro-Septic training provided by Chankar Environmental.

The online training provided by Chankar Environmental is product specific and must be used in conjunction with relevant guidelines and regulations. <https://enviro-septic.com.au/the-process-of-certification/>

To obtain the name of a qualified person in your area, contact our customer service department on: (07) 5474 4055.

For maintenance on the pumping station, if applicable, the owner must refer to the user guide specified by the manufacturer of these systems.

The pumping out of the septic tank must be performed by a company specialising in that field. Check with your local council for the companies in your area that are qualified to do this.

Warranty

AES Pipes

Warranty

AES Pipes



Presby Environmental Inc.

PRESBY ENVIRONMENTAL INC. STANDARD LIMITED WARRANTY

- a) The structural integrity of each unit, endcap and other accessory manufactured by Presby Environmental Inc. (collectively referred to as "Units"), when installed and operated in an onsite wastewater system in accordance with Presby Environmental's installation instructions, is warranted to the original purchaser ("Holder") against defective materials and workmanship for one year from the date upon which a septic permit is issued for the septic system containing the Units; provided, however, that if a septic permit is not required for the septic system by applicable law, the one (1) year warranty period will begin upon the date that installation of the septic system commences.

In order to exercise its warranty rights, Holder must notify Presby Environmental in writing at its corporate headquarters in Whitefield, New Hampshire within fifteen (15) days of the alleged defect. Presby Environmental will supply replacement Units for those Units determined by Presby Environmental to be defective and covered by this Limited Warranty. Presby Environmental's liability specifically excludes the cost of removal and/or installation of the Units.

- b) THE LIMITED WARRANTY AND REMEDIES IN SUBPARAGRAPH (a) ARE EXCLUSIVE. THERE ARE NO OTHER WARRANTIES WITH RESPECT TO THE UNITS, INCLUDING NO IMPLIED WARRANTIES OF MERCHANTABILITY OR FITNESS FOR A PARTICULAR PURPOSE.
- c) This Limited Warranty shall be void if any part of the Presby Environmental system (unit, endcap or other accessory) is manufactured by anyone other than Presby Environmental. The Limited Warranty does not extend to incidental, consequential, special or indirect damages.

Presby Environmental shall not be liable for penalties or liquidated damages, including loss of production and profits, labor and materials, overhead costs, or other losses or expenses incurred by the Holder or any third party.

Specifically excluded from Limited Warranty coverage are damage to the Units due to ordinary wear and tear, alteration, accident, misuse, abuse or neglect of the Units; the Units being subjected to vehicle traffic or other conditions which are not permitted by the installation instructions; failure to maintain the minimum ground covers set forth in the installation instructions; the placement of improper materials into the system containing the Units; failure of the Units or the septic system due to improper siting or improper sizing, excessive water usage, improper grease disposal, or improper operation; or any other event not caused by Presby Environmental.

This Limited Warranty shall be void if the Holder fails to comply with all of the terms set forth in this Limited Warranty.

- d) No representative of Presby Environmental has the authority to change this Limited Warranty in any manner whatsoever, or to extend this Limited Warranty. No warranty applies to any party other than the original Holder.

Further, in no event shall Presby Environmental be responsible for any loss or damage to the Holder, the Units, or any third party resulting from installation or shipment, or from any product liability claims of Holder or any third party. For this Limited Warranty to apply, the Units must be installed in accordance with all site conditions required by state and local codes; all other applicable laws; and Presby Environmental's installation instructions.

The above represents the standard Limited Warranty offered by Presby Environmental. A limited number of states and counties have different warranty requirements. Any purchaser of Units should contact Presby Environmental's corporate headquarters in Whitefield, New Hampshire, prior to such purchase, to obtain a copy of the applicable warranty, and should carefully read that warranty prior to the purchase of Units.

Warranty

AES Pipes

Warranty Other Components

Other components such as the Septic Tank, Pumps, Pumpwells and other components if fitted, refer to the individual manufacturer warranties.

Attachment 3: AES-38 and AES-38-SPD* Product Specifications and Schematic diagrams

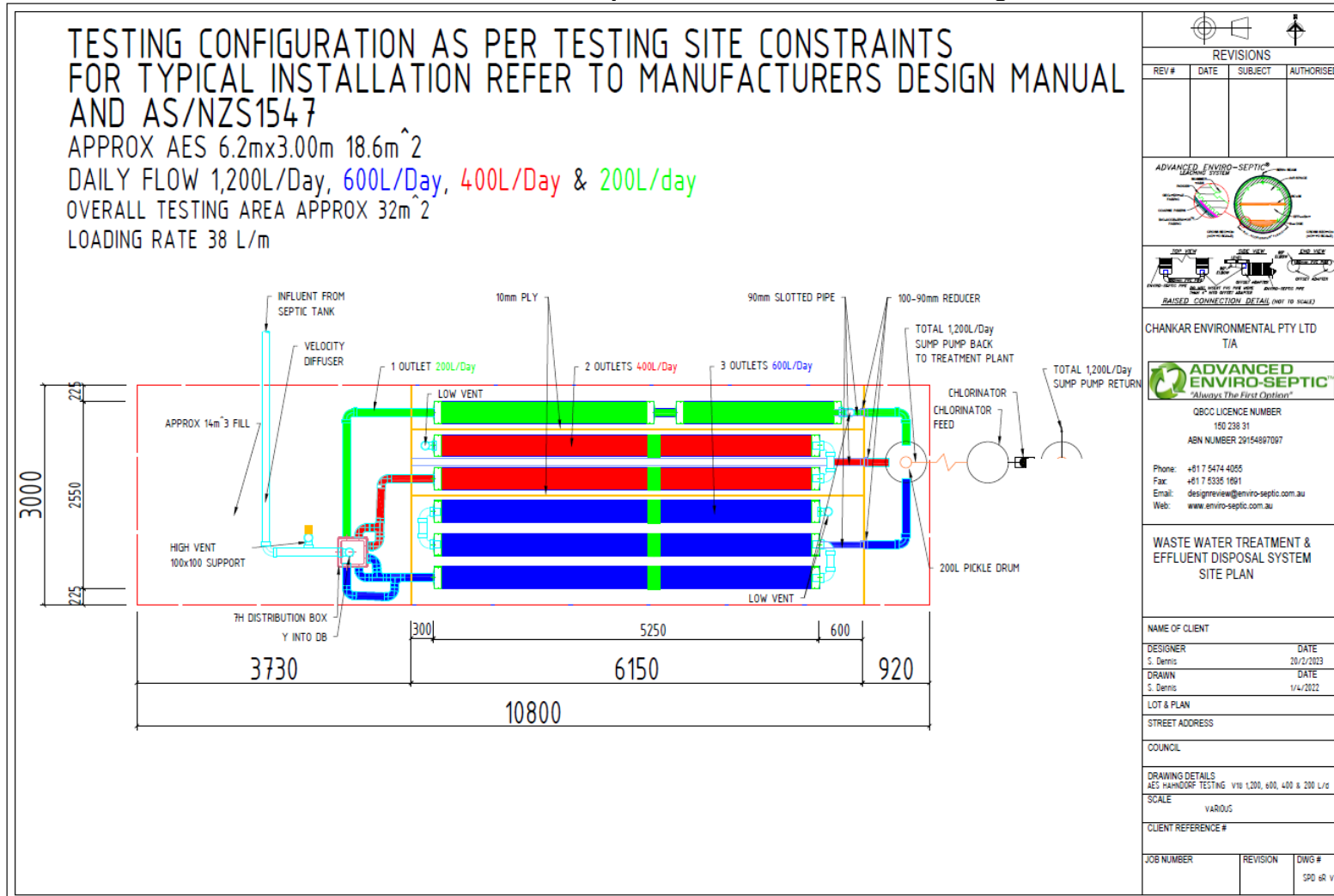

*The AES-38-SPD variant must also have a liner.

TESTING CONFIGURATION AS PER TESTING SITE CONSTRAINTS FOR TYPICAL INSTALLATION REFER TO MANUFACTURERS DESIGN MANUAL AND AS/NZS1547

AES STORAGE VOLUME 1,200 L/d 6 ROWS 2,544L
 AES STORAGE VOLUME 600 L/d 4 ROWS 1,272L
 AES STORAGE VOLUME 400 L/d 2 ROWS 848L
 AES STORAGE VOLUME 200 L/d 1 ROW 445L

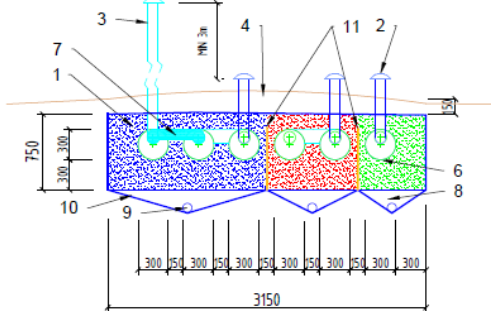
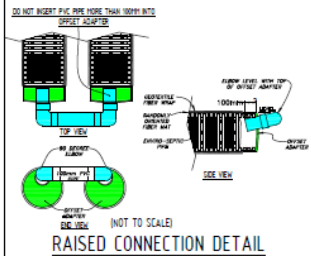
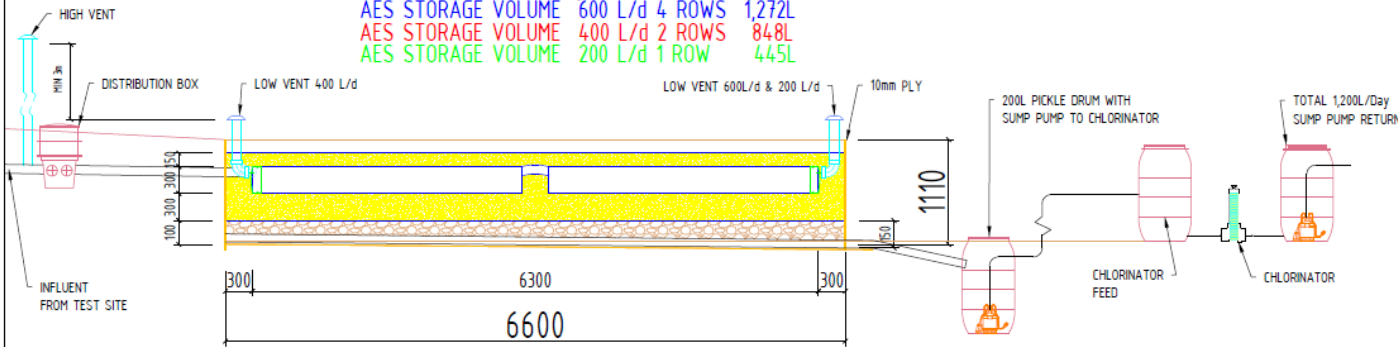

- SPD SECTION VIEW**
- | ITEM | DETAILS |
|------|--|
| 1 | APPROVED SAND |
| 2 | LOW VENT |
| 3 | HIGH VENT MIN 3m HIGHER THAN LOW VENT. (IF PUMPED) ELSE GRAVITY, HOUSE VENT MIN 2x50mm DIAM OR 1x80MM DIAM |
| 4 | TOP SOIL/GRASS. MOUNDED OVER AES BED |
| 6 | AES PIPE |
| 7 | RAISED CONNECTOR |
| 8 | 10-20mm DRAINAGE AGGREGATE |
| 9 | 90mmØ SLOTTED COLLECTION PIPE REFER TO LINED AES BED NOTES |
| 10 | 200micron HEAVY DUTY LDPE LINER REFER TO LINED AES BED NOTES |
| 11 | 10mm MARINE PLY |

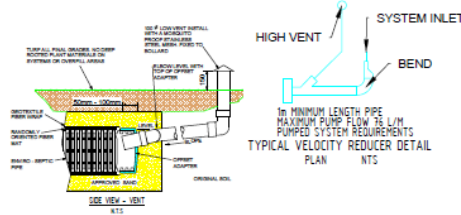
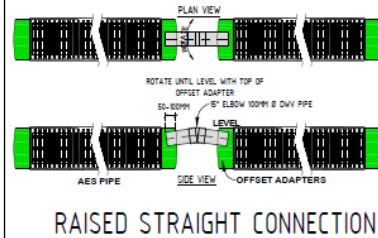

- LINED AES BED NOTES**
- LINING MEMBRANE TO HAVE 25 YEAR MINIMUM DESIGN LIFE MINIMUM 200 MICRON HEAVY DUTY LDPE.
 - LINING TO COVER ENTIRE BED INCLUDING TOP SURFACE
 - COLLECTION PIPE 90mmØ DWV SLOTTED
 - FLANGE TANK FITTING TO SUITE DIAMETER OF SLOTTED DRAINAGE PIPE

REVISIONS			
REV #	DATE	SUBJECT	AUTHORISED

CHANKAR ENVIRONMENTAL PTY LTD
T/A

ADVANCED ENVIRO-SEPTIC™
"Always The First Option"

QBCC LICENCE NUMBER
150 238 31
ABN NUMBER 20154897097

Phone: +61 7 5474 4055
 Fax: +61 7 5335 1691
 Email: designreview@enviro-septic.com.au
 Web: www.enviro-septic.com.au

WASTE WATER TREATMENT & EFFLUENT DISPOSAL SYSTEM SITE PLAN

NAME OF CLIENT

DESIGNER	DATE
S. Dennis	20/2/2023
DRAWN	DATE
S. Dennis	1/4/2022

LOT & PLAN

STREET ADDRESS

COUNCIL

DRAWING DETAILS
AES HAHNDORF V10 1,200, 600,400 & 200 L/d

SCALE
VARIOUS

CLIENT REFERENCE #

JOB NUMBER	REVISION	DWG #
		SPD 0R V10

*The AES-38-SPD variant must also have a liner.